

Description

The DL3354S2-5 is a high performance design which includes surge rated diode arrays to protect high speed data interfaces. The DL3354S2-5 has been specifically designed to protect sensitive components, which are connected to data and transmission lines, from over-voltage caused by Electrostatic Discharging(ESD), Electrical Fast Transients(EFT), and Lightning. It is a unique design which includes surge rated, low capacitance steering diodes and a unique design of clamping cell which is an equivalent TVS diode in a single package. During transient conditions, the steering diodes direct the transient to either the power supply line or to the ground line. The internal unique design of clamping cell prevents over-voltage on the power line, protecting any downstream components.

Mechanical Characteristics

- ◆ Package: SOT23-5L
- ◆ UL Flammability Classification Rating 94V-0
- ◆ Case Material: "Green" Molding Compound
- ◆ Moisture Sensitivity: Level 3 per J-STD-020
- ◆ Terminal Connections: See Diagram Below
- ◆ Marking Information: See Below

Dimensions and Pin Configuration

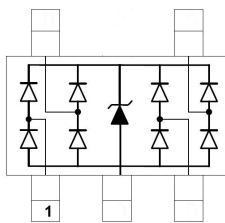

Circuit and Pin Schematic

Features

- ◆ Low capacitance: 1.5pF typical (I/O to I/O)
- ◆ Low operating voltage: 3.3V
- ◆ Fast turn-on and Low clamping voltage
- ◆ Array of surge rated diodes with internal equivalent TVS diode
- ◆ ESD Protect for 2 high-speed I/O channels
- ◆ Complies with following standards:
 - IEC 61000-4-2 (ESD) immunity test
Air discharge: ±30kV
Contact discharge: ±30kV
 - IEC61000-4-4 (EFT) 40A (5/50ns)
 - IEC61000-4-5 (Lightning) : 22A(8/20µs)
- ◆ ROHS Compliant

Applications

- ◆ USB 2.0 power and data line
- ◆ Notebook and PC Computers
- ◆ Monitors and Flat Panel Displays
- ◆ IEEE 1394 Firewire Ports
- ◆ Video Graphics Cards
- ◆ SIM Ports

Marking Information

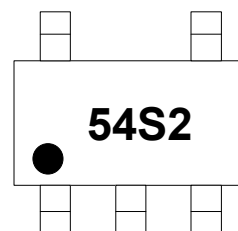

54S2 = Device Marking Code

Dot denotes Pin1

Ordering Information

Part Number	Marking	Packaging	Reel Size
DL3354S2-5	54S2	3000/Tape & Reel	7 inch

Absolute Maximum Ratings ($T_A=25^{\circ}\text{C}$ unless otherwise specified)

Parameter	Symbol	Value	Unit
Peak Pulse Power (8/20 μs)	Ppk	300	W
Peak Pulse Current (8/20 μs)	I _{PP}	22	A
ESD per IEC 61000-4-2 (Air)	V _{ESD}	± 30	kV
ESD per IEC 61000-4-2 (Contact)		± 30	
Operating Temperature Range	T _J	-55 to +125	$^{\circ}\text{C}$
Storage Temperature Range	T _{stg}	-55 to +150	$^{\circ}\text{C}$

Electrical Characteristics ($T_A=25^{\circ}\text{C}$ unless otherwise specified)

Parameter	Symbol	Min	Typ	Max	Unit	Test Condition
Reverse Working Voltage	V _{RWM}			3.3	V	Any I/O pin to ground
Breakdown Voltage	V _{PT}	3.5			V	I _T = 2 μA , any I/O pin to ground
Snap-Back Voltage	V _{SB}	2.8			V	I _T = 50mA, any I/O pin to ground
Reverse Leakage Current	I _R			0.5	μA	V _{RWM} = 3.3V, any I/O pin to ground
Clamping Voltage	V _C			6	V	I _{PP} = 1A (8 x 20 μs pulse), any I/O pin to ground
Clamping Voltage	V _C			14	V	I _{PP} = 22A (8 x 20 μs pulse), any I/O pin to ground
Junction Capacitance	C _J		1.5		pF	V _R = 0V, f = 1MHz, between I/O pins
Junction Capacitance	C _J		3	5	pF	V _R = 0V, f = 1MHz, any I/O pin to ground

Typical Performance Characteristics (TA=25°C unless otherwise Specified)

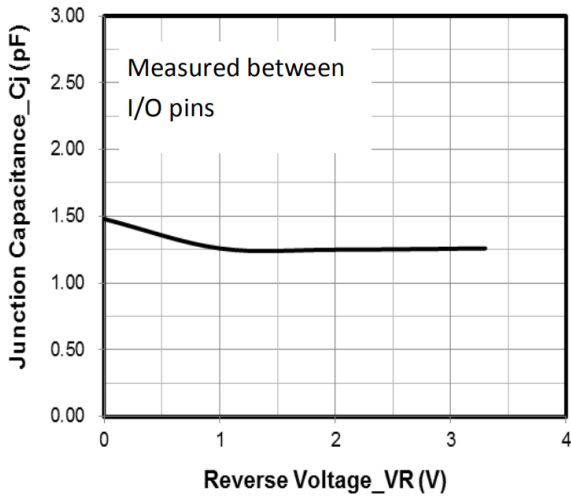

Junction Capacitance vs. Reverse Voltage

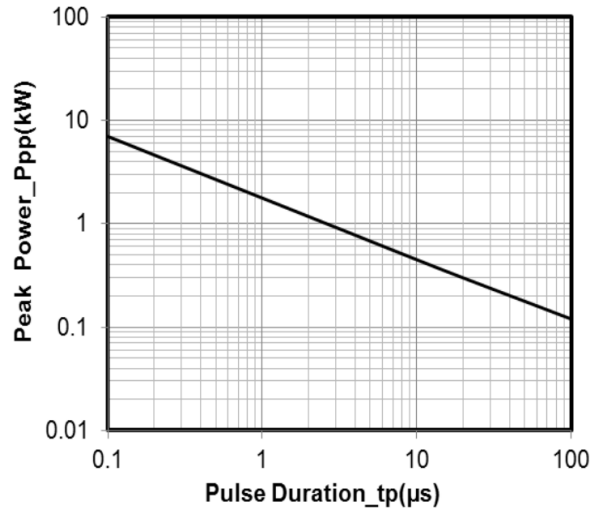

Peak Pulse Power vs. Pulse Time

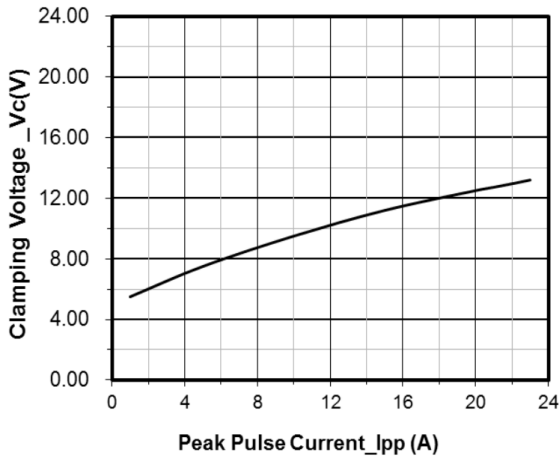

Clamping Voltage vs. Peak Pulse Current

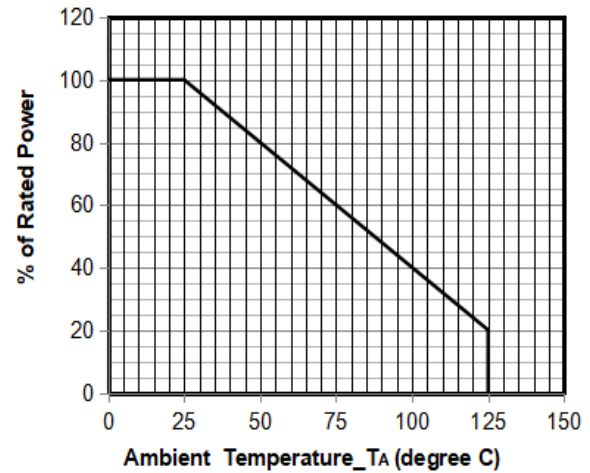

Power Derating Curve

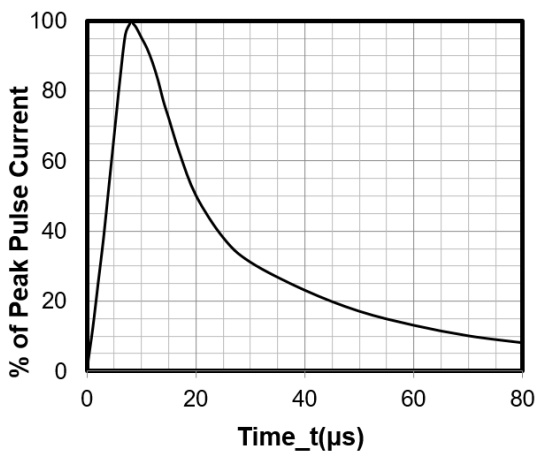

8 X 20μs Pulse Waveform

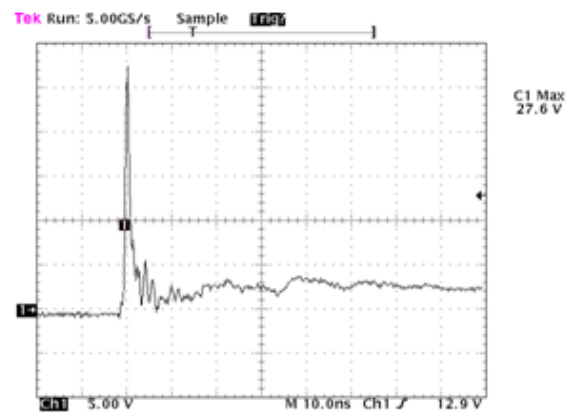

Note: Data is taken with a 10x attenuator

ESD Clamping Voltage

8 kV Contact per IEC61000-4-2

SOT23-5L Package Outline Drawing

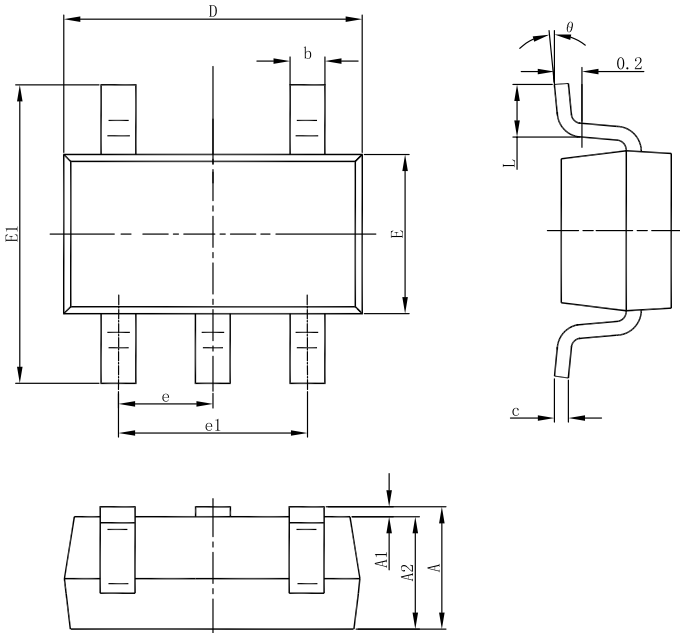

Symbol	Dimensions			
	Millimeters		Inches	
	Min	Max	Min	Max
A	1.050	1.250	0.041	0.049
A1	0.000	0.100	0.000	0.004
A2	1.050	1.150	0.041	0.045
b	0.300	0.500	0.012	0.020
c	0.100	0.200	0.004	0.008
D	2.820	3.020	0.111	0.119
E	1.500	1.700	0.059	0.067
E1	2.650	2.950	0.104	0.116
e	0.950(BSC)		0.037(BSC)	
e1	1.800	2.000	0.071	0.079
L	0.300	0.600	0.012	0.024
theta	0°	8°	0°	8°

Suggested Land Pattern

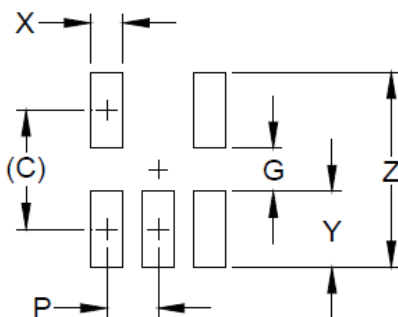

SYM	DIMENSIONS	
	MILLIMETERS	INCHES
C	2.50	0.098
G	1.40	0.055
P	0.95	0.037
X	0.60	0.024
Y	1.10	0.043
Z	3.60	0.141

Contact Information

Changzhou D-first Electronics CO.,Ltd.

www.first-electronic.com

Email: xhf@first-electronic.cn

Phone: +86 (0519) -8817 1671